

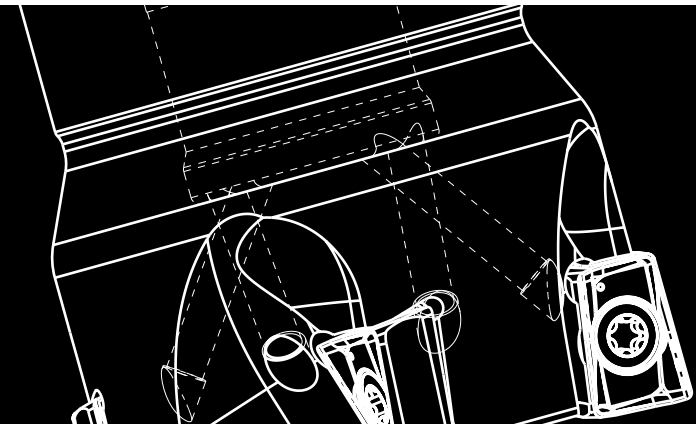

smart solutions manufacturer[®]
WE MAKE IT REAL.



CUTTING TOOLS
MILLING SOLUTIONS & SPARE PARTS

FRÄSWERKZEUGE
FRÄSANWENDUNGEN VERFÜGT & ZUBEHÖR



smart solutions manufacturing
WE MAKE IT REAL.

HIGH PERFORMANCE ROUGHING | SCHRUPPEN > SOEW08

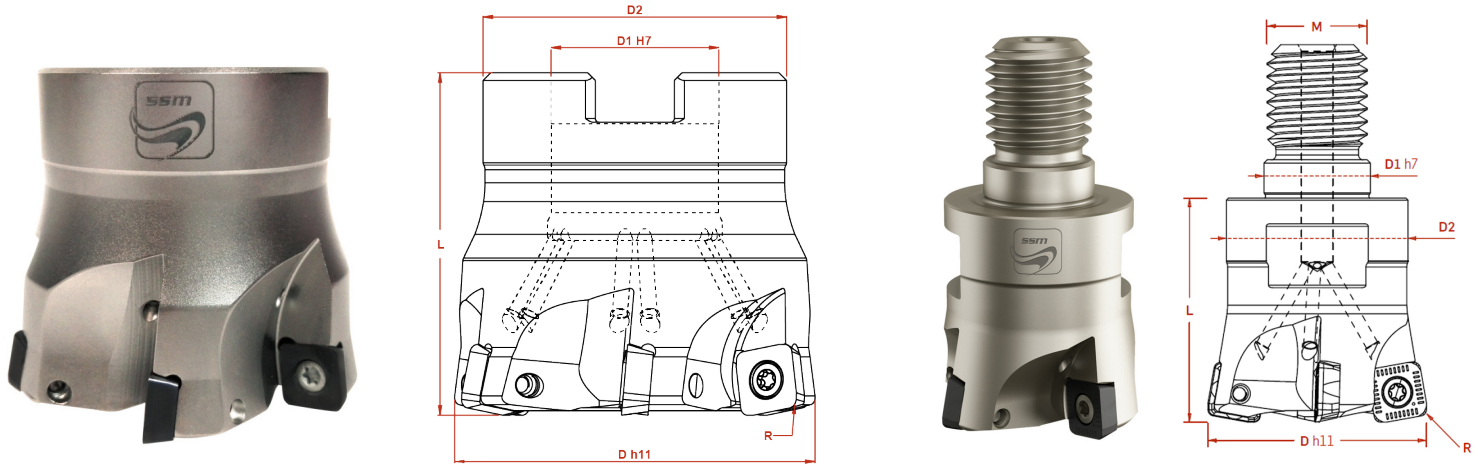

Code Produktcode	Typology Typologie	€ (P.V.P)	Dimensions (mm) Abmessungen (mm)							Spare Parts Zubehör	
			α	D	D1	L	D2	M	Z		
052A46010-Z6-02	Arbor	-	10°	52	22	45	40	-	6	P30.83.43	CHT9
066A46010-Z7-02	Arbor	-	10°	66	27	50	48	-	7	P30.83.43	CHT9
020R46010-Z2-02-M10	Modular	-	10°	20	10.5	25	16	M10	2	P30.83.43	CHT9
025R46010-Z3-02-M12	Modular	-	10°	25	12.5	28	21	M12	3	P30.83.43	CHT9
032R46010-Z4-02-M16	Modular	-	10°	32	17	35	29	M16	4	P30.83.43	CHT9
035R46010-Z4-02-M16	Modular	-	10°	35	17	35	29	M16	4	P30.83.43	CHT9
042R46010-Z5-02-M16	Modular	-	10°	42	17	35	29	M16	5	P30.83.43	CHT9

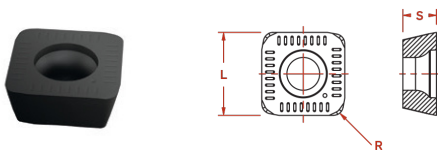

HIGH FEED SQUARE INSERTS | QUADRATISCHE WENDESCHNEIDPLATTEN FÜR GROSSE VORSCHUB > SOEW08

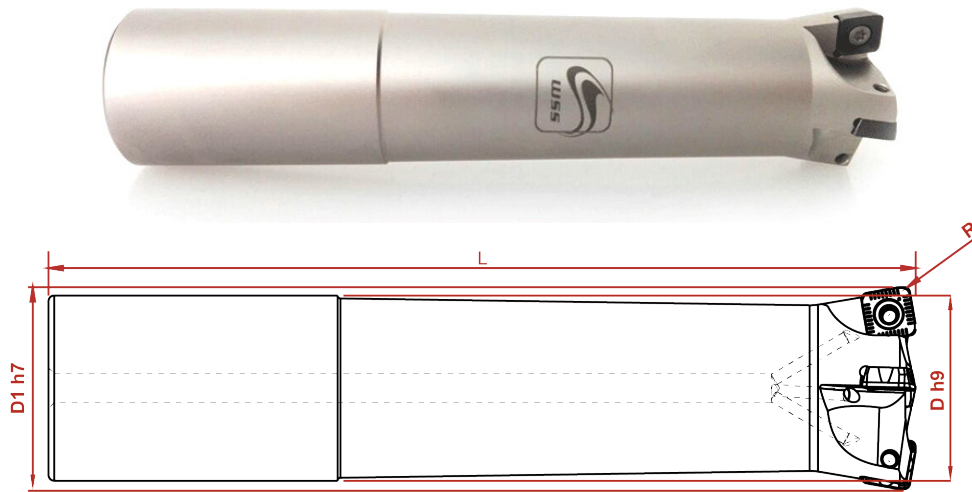

Code Produktcode	Dimensions (mm) Abmessungen (mm)			GRADE											
	L	S	R	P35	€	P30	€	P25	€	P20	€	P10	€	K03	€
SOEW 080310 S	8.60	3.48	2	<input checked="" type="checkbox"/>	-	<input checked="" type="checkbox"/>	-	<input checked="" type="checkbox"/>	-	<input checked="" type="checkbox"/>	-	<input checked="" type="checkbox"/>	-	<input checked="" type="checkbox"/>	-

HIGH PERFORMANCE ROUGHING | SCHRUPPEN > SOEW08



Code Produktcode	Typology Typologie	€ (P.V.P)	Dimensions (mm) Abmessungen (mm)							Spare Parts Zubehör	
			α	D	D1	L	D2	M	Z		
021G46010-Z2-02-L125	Haste Shank	-	10°	21	20	125	-	-	2	P30.83.43	CHT9
025G46010-Z3-02-L125	Haste Shank	-	10°	25	25	125	-	-	3	P30.83.43	CHT9
035G46010-Z4-02-L150	Haste Shank	-	10°	35	32	150	-	-	4	P30.83.43	CHT9

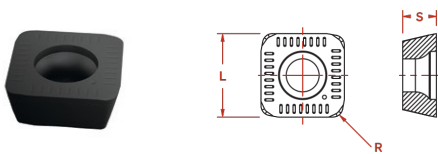

HIGH FEED SQUARE INSERTS | QUADRATISCHE WENDESCHNEIDPLATTEN FÜR GROSSE VORSCHUB > SOEW08

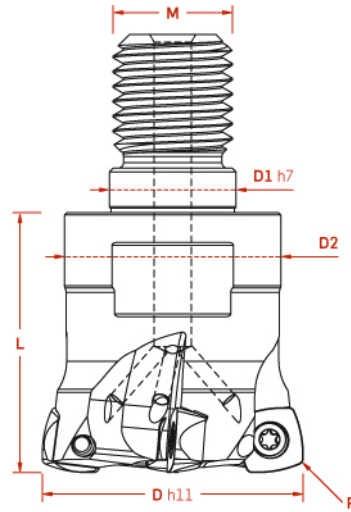

Code Produktcode	Dimensions (mm) Abmessungen (mm)			GRADE											
	L	S	R	P35	€	P30	€	P25	€	P20	€	P10	€	K03	€
SOEW 080310 S	8.60	3.48	2	<input checked="" type="checkbox"/>	-	<input checked="" type="checkbox"/>	-	<input checked="" type="checkbox"/>	-	<input checked="" type="checkbox"/>	-	<input checked="" type="checkbox"/>	-	<input checked="" type="checkbox"/>	-

HIGH PERFORMANCE ROUGHING | SCHRUPPEN SPKW08



Code Produktcode	Typology Typologie	€ (P.V.P)	α	Dimensions (mm) Abmessungen (mm)						Spare Parts Zubehör	
				D	D1	L	D2	M	Z		
020R56090-Z2-05-M10	Modular	-	90°	20	10.5	25	16	M10	2	P30.83.43	CHT9
025R56090-Z3-05-M12	Modular	-	90°	25	12.5	28	21	M12	3	P30.83.43	CHT9
032R56090-Z4-05-M16	Modular	-	90°	32	17	35	29	M16	4	P30.83.43	CHT9
035R56090-Z4-05-M16	Modular	-	90°	35	17	35	29	M16	4	P30.83.43	CHT9
042R56090-Z5-05-M16	Modular	-	90°	42	17	35	29	M16	5	P30.83.43	CHT9

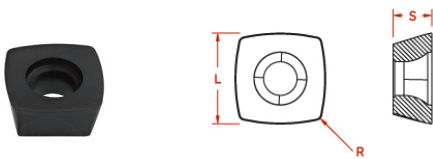

HIGH FEED SQUARE INSERTS | QUADRATISCHE WENDESCHNEIDPLATTEN FÜR GROSSE VORSCHUB > SPKW08

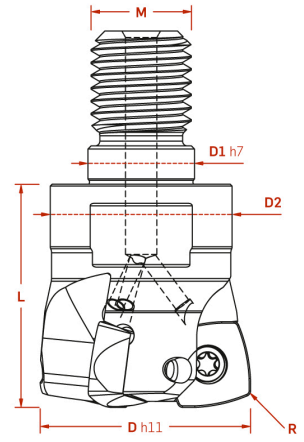
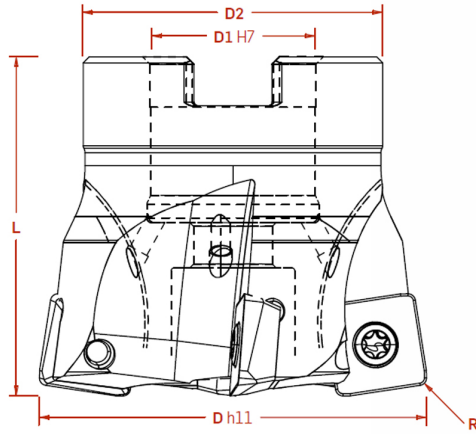

Code Produktcode	Dimensions (mm) Abmessungen (mm)			GRADE											
	L	S	R	P35	€	P30	€	P25	€	P20	€	P10	€	K03	€
SPKT 08T308 E	8.5	3.97	1.8	✘	-	✘	-	✘	-	▲	-	✘	-	✘	-
SPKW 08T308 E	8.5	3.97	1.8	✘	-	✘	-	✘	-	▲	-	✘	-	✘	-

HIGH PERFORMANCE ROUGHING | SCHRUPPEN > SOEW13/SPKW13



Code Produktcode	Typology Typologie	€ (P.V.P)	Dimensions (mm) Abmessungen (mm)							Spare Parts Zubehör	
			α	D	D1	L	D2	M	Z		
050A66090-Z4-05	Arbor	-	90°	50	22	45	40	-	4	P40.111.55	CHT15
050A66090-Z5-05	Arbor	-	90°	50	22	45	40	-	5	P40.111.55	CHT15
052A66090-Z4-05	Arbor	-	90°	52	22	45	40	-	4	P40.111.55	CHT15
052A66090-Z5-05	Arbor	-	90°	52	22	45	40	-	5	P40.111.55	CHT15
063A66090-Z5-05	Arbor	-	90°	63	27	50	48	-	5	P40.111.55	CHT15
066A66090-Z5-05	Arbor	-	90°	66	27	50	48	-	5	P40.111.55	CHT15
080A66090-Z6-05	Arbor	-	90°	80	27	50	60	-	6	P40.111.55	CHT15
100A66090-Z8-05	Arbor	-	90°	100	32	50	70	-	8	P40.111.55	CHT15
035R66090-Z3-05-M16	Modular	-	90°	35	17	35	29	M16	3	P40.111.55	CHT15
040R66090-Z4-05-M16	Modular	-	90°	40	17	35	29	M16	4	P40.111.55	CHT15

HIGH FEED SQUARE INSERTS | QUADRATISCHE WENDESCHNEIDPLATTEN FÜR GROSSE VORSCHUB > SOEW13/SPKW13

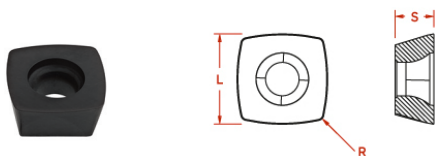

Code Produktcode	Dimensions (mm) Abmessungen (mm)			GRADE											
	L	S	R	P35	€	P30	€	P25	€	P20	€	P10	€	K03	€
SOEW 13M510 S	13	5.5	2.5	▲	-	✘	-	✘	-	▲	-	▲	-	✘	-
SPKT 130510 E	13	5.56	2.5	✘	-	✘	-	✘	-	▲	-	✘	-	✘	-
SPKW 130510 S	13	5.56	2.5	▲	-	✘	-	✘	-	▲	-	▲	-	✘	-



▲ Stock | aus Lagervorrat lieferbar

▲ Available under request | auf Anfrage erhältlich

✘ Not available | Nicht verfügbar

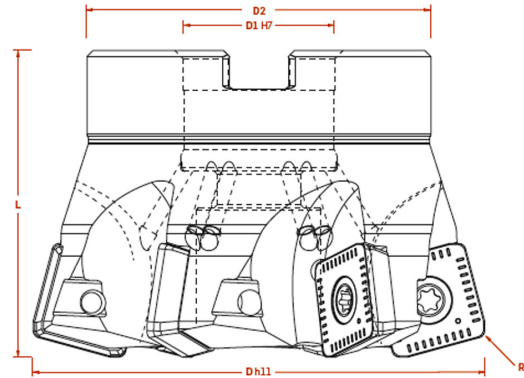
HIGH PERFORMANCE ROUGHING | SCHRUPPEN > SOEW16



Code Produktcode	Typology Typologie	€ (P.V.P)	Dimensions (mm) Abmessungen (mm)							Spare Parts Zubehör	
			α	D	D1	L	D2	M	Z		
080A86015-Z6-02	Arbor	-	15°	80	27	50	60	-	6	P50.120.55	CHT20
100A86015-Z8-02	Arbor	-	15°	100	27	52	70	-	8	P50.120.55	CHT20
125A86015-Z10-02	Arbor	-	15°	125	40	63	90	-	10	P50.120.55	CHT20

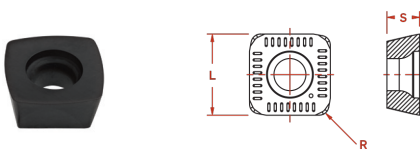

PASHIGH FEED SQUARE INSERTS | QUADRATISCHE WENDESCHNEIDPLATTEN FÜR GROSSE VORSCHUB > SOEW16

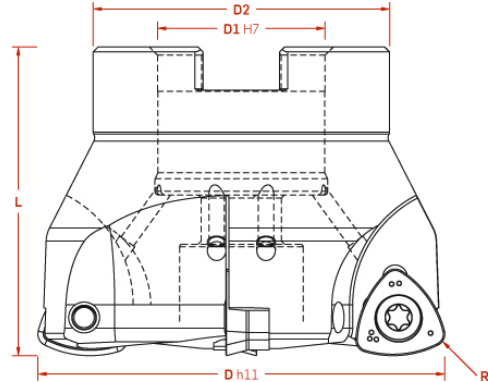

Code Produktcode	Dimensions (mm) Abmessungen (mm)			GRADE											
	L	S	R	P35	€	P30	€	P25	€	P20	€	P10	€	K03	€
SOEW 160512 S	16.40	5.26	4.5	▲	-	✘	-	✘	-	▲	-	▲	-	✘	-

ROUGHING HIGH OVERHANG | SCHRUPPEN MIT GROSSER ZUSTELLTIEFE > WNMW



Code Produktcode	Typology Typologie	€ (P.V.P)	Dimensions (mm) Abmessungen (mm)							Spare Parts Zubehör	
			α	D	D1	L	D2	M	Z		
052A00560-Z3	Arbor	-	60°	52	22	44	42	-	3	P45.105.66	CHT20
063A00560-Z4	Arbor	-	60°	63	27	50	48	-	4	P45.105.66	CHT20
066A00560-Z4	Arbor	-	60°	66	27	50	48	-	4	P45.105.66	CHT20
080A00560-Z5	Arbor	-	60°	80	27	50	60	-	5	P45.105.66	CHT20

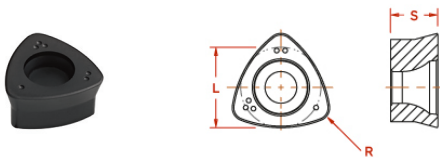

HIGH FEED TRIANGULAR INSERTS | DREIECKIGE SCHNEIDPLATTEN FÜR SCHNELLEN VORSCHUB > WNMW

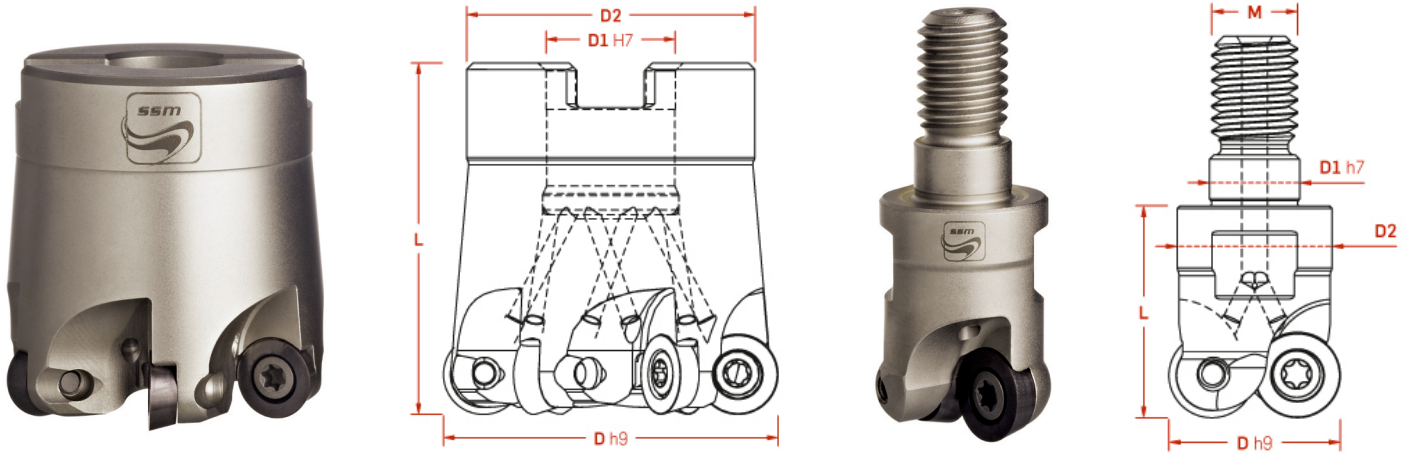

Code Produktcode	Dimensions (mm) Abmessungen (mm)			GRADE											
	L	S	R	P35	€	P30	€	P25	€	P20	€	P10	€	K03	€
WNMW 1207-SP	12	7	2	▲	-	✘	-	▲	-	▲	-	▲	-	✘	-

SEMI-ROUGHING & FINISHING | RUNDE WENDESCHNEIDPLATTEN > RD10



Code Produktcode	Typology Typologie	€ (P.V.P)	Dimensions (mm) Abmessungen (mm)							Spare Parts Zubehör	
			α	D	D1	L	D2	M	Z		
042A05290-Z6	Arbor	-	90°	42	16	44	36	-	6	P35.67.53	CHT15
052A05290-Z7	Arbor	-	90°	52	22	50	40	-	7	P35.67.53	CHT15
066A05290-Z7	Arbor	-	90°	66	27	50	48	-	7	P35.67.53	CHT15
020R05290-Z2-M10	Modular	-	90°	20	10,5	26	18	M10	2	P35.67.53	CHT15
025R05290-Z3-M12	Modular	-	90°	25	12,5	30	21	M12	3	P35.67.53	CHT15
030R05290-Z4-M16	Modular	-	90°	30	17	36	29	M16	4	P35.67.53	CHT15
035R05290-Z5-M16	Modular	-	90°	35	17	40	29	M16	5	P35.67.53	CHT15
042R05290-Z5-M16	Modular	-	90°	42	17	40	29	M16	5	P35.67.53	CHT15

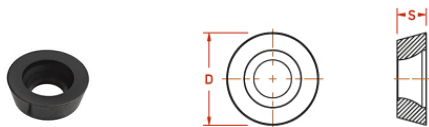

ROUND INSERTS | RUNDE WENDESCHNEIDPLATTEN > RD10

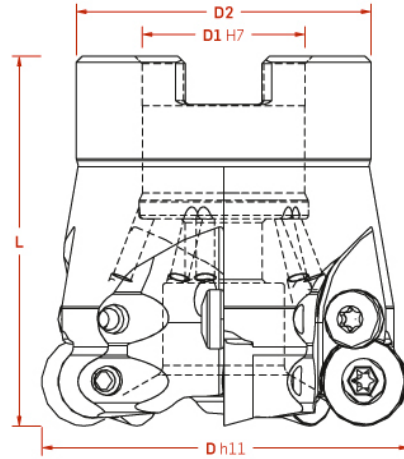

Code Produktcode	Dimensions (mm) Abmessungen (mm)			GRADE											
	D	S	R	P35	€	P30	€	P25	€	P20	€	P10	€	K03	€
RDHT 1003 MOT	10	3.18	-	▲	-	✘	-	▲	-	✘	-	✘	-	✘	-
RDHW 1003 MOT	10	3.18	-	▲	-	✘	-	✘	-	▲	-	▲	-	▲	-
RDMT 1003 MOT	10	3.18	-	▲	-	✘	-	▲	-	✘	-	✘	-	✘	-
RDMW 1003 MOT	10	3.18	-	▲	-	✘	-	▲	-	▲	-	✘	-	✘	-

SEMI-ROUGHING & FINISHING | RUNDE WENDESCHNEIDPLATTEN > RD12



Code Produktcode	Typology Typologie	€ (P.V.P)	Dimensions (mm) Abmessungen (mm)							Spare Parts Zubehör	
			α	D	D1	L	D2	M	Z		
050A15290-Z5-07	Arbor	-	90°	50	22	50	40	-	5	P35.93.53	CHT15
052A15290-Z5	Arbor	-	90°	52	22	50	40	-	5	P35.93.53	CHT15
052A15290-Z5-07	Arbor	-	90°	52	22	50	40	-	5	P35.93.53	CHT15
066A15290-Z6-07	Arbor	-	90°	66	27	50	48	-	6	P35.93.53	CHT15
080A15290-Z7-07	Arbor	-	90°	80	27	50	60	-	7	P35.93.53	CHT15

ROUND INSERTS | RUNDE WENDESCHNEIDPLATTEN > RD12

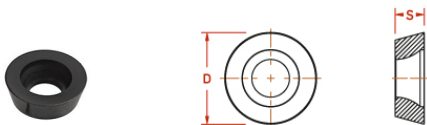

Code Produktcode	Dimensions (mm) Abmessungen (mm)			GRADE											
	D	S	R	P35	€	P30	€	P25	€	P20	€	P10	€	K03	€
RDHT 12T3 MOT	12	3.97	-	✘	-	✘	-	✘	-	▲	-	✘	-	✘	-
RDHW 12T3 MOT	12	3.97	-	▲	-	✘	-	✘	-	▲	-	▲	-	▲	-
RDMT 12T3 MOT	12	3.97	-	▲	-	✘	-	▲	-	✘	-	✘	-	✘	-
RDMW 12T3 MOT	12	3.97	-	▲	-	✘	-	▲	-	▲	-	✘	-	✘	-

SEMI-ROUGHING & FINISHING | RUNDE WENDESCHNEIDPLATTEN > RD12

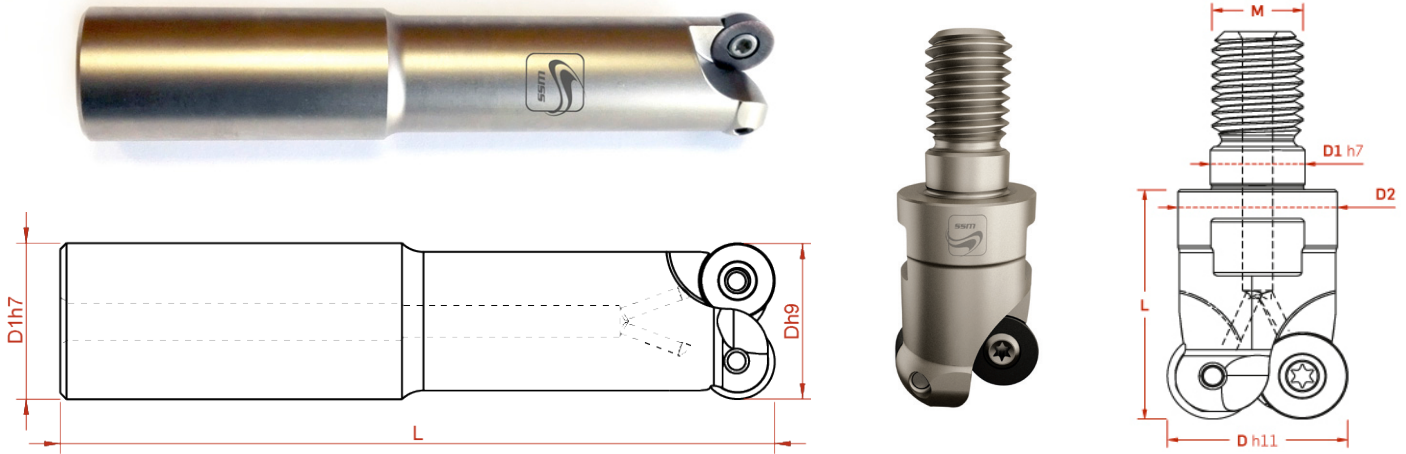

Code Produktcode	Typology Typologie	€ (P.V.P)	Dimensions (mm) Abmessungen (mm)							Spare Parts Zubehör	
			α	D	D1	L	D2	M	Z		
025G15290-Z2-130	Haste Shank	-	90°	25	25	130	-	-	2	P35.93.53	CHT15
024R15290-Z2-M12	Modular	-	90°	24	12,5	32	21	M12	2	P35.93.53	CHT15
035R15290-Z3-M16	Modular	-	90°	35	17	42	29	M16	3	P35.93.53	CHT15
042R15290-Z4-M16	Modular	-	90°	42	17	42	29	M16	4	P35.93.53	CHT15

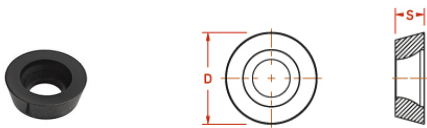

ROUND INSERTS | RUNDE WENDESCHNEIDPLATTEN > RD12

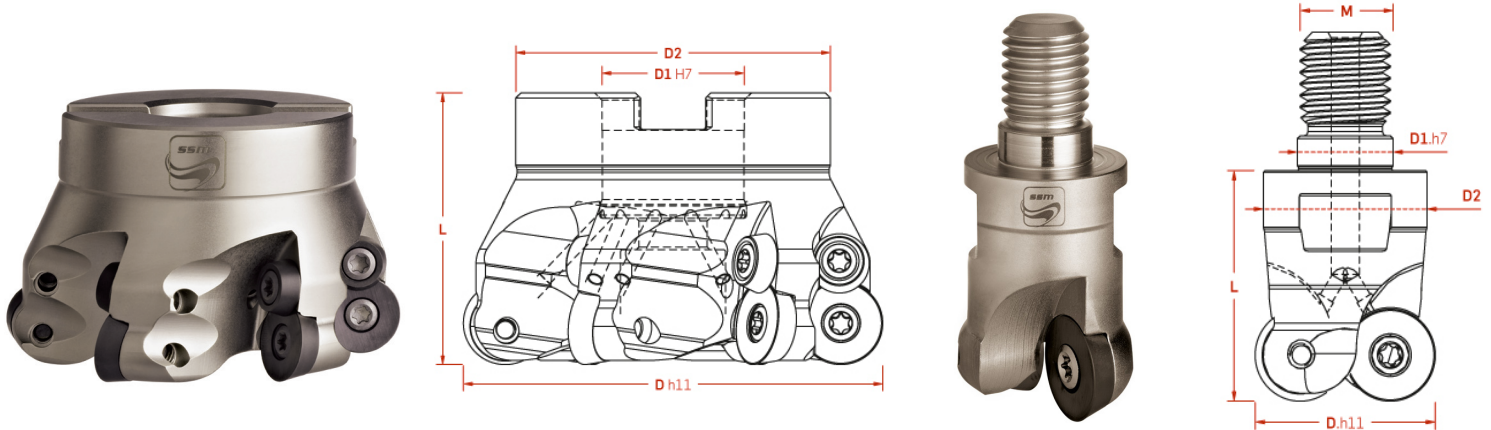

Code Produktcode	Dimensions (mm) Abmessungen (mm)			GRADE											
	D	S	R	P35	€	P30	€	P25	€	P20	€	P10	€	K03	€
RDHT 12T3 MOT	12	3.97	-	✘	-	✘	-	✘	-	▲	-	✘	-	✘	-
RDHW 12T3 MOT	12	3.97	-	▲	-	✘	-	✘	-	▲	-	▲	-	▲	-
RDMT 12T3 MOT	12	3.97	-	▲	-	✘	-	▲	-	✘	-	✘	-	✘	-
RDMW 12T3 MOT	12	3.97	-	▲	-	✘	-	▲	-	▲	-	✘	-	✘	-

SEMI-ROUGHING & FINISHING | RUNDE WENDESCHNEIDPLATTEN > RD16



Code Produktcode	Typology Typologie	€ (P.V.P)	Dimensions (mm) Abmessungen (mm)							Spare Parts Zubehör	
			α	D	D1	L	D2	M	Z		
050C25290-Z4	Arbor	-	90°	50	22	50	40	-	4	P45.105.66	CHT20
052C25290-Z4	Arbor	-	90°	52	22	50	40	-	4	P45.105.66	CHT20
052C25290-Z4-07	Arbor	-	90°	52	22	50	40	-	4	P45.105.66	CHT20
063A25290-Z5-07	Arbor	-	90°	63	27	50	48	-	5	P45.105.66	CHT20
066C25290-Z5	Arbor	-	90°	66	27	50	48	-	5	P45.105.66	CHT20
066C25290-Z5-07	Arbor	-	90°	66	27	50	48	-	5	P45.105.66	CHT20
080C25290-Z6-07	Arbor	-	90°	80	27	52	60	-	6	P45.105.66	CHT20
125A25290-Z8-07	Arbor	-	90°	125	40	52	90	-	8	P45.105.66	CHT20
160A25290-Z9-07	Arbor	-	90°	160	40	52	90	-	9	P45.105.66	CHT20
032R25290-Z2-M16	Modular	-	90°	32	17	40	29	M16	2	P45.105.66	CHT20

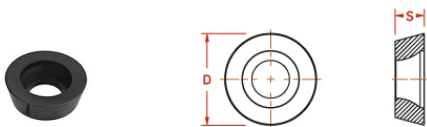

ROUND INSERTS | RUNDE WENDESCHNEIDPLATTEN > RD16

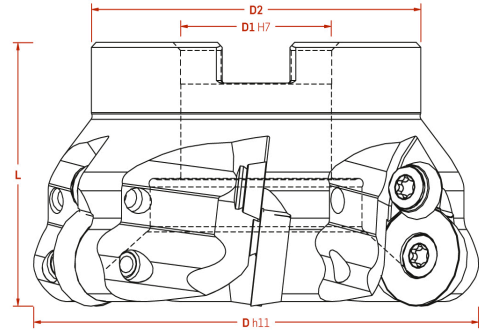

Code Produktcode	Dimensions (mm) Abmessungen (mm)			GRADE											
	D	S	R	P35	€	P30	€	P25	€	P20	€	P10	€	K03	€
RDHT 1604 MOT	16	4.76	-	✘	-	✘	-	✘	-	▲	-	✘	-	✘	-
RDHW 1604 MOT	16	4.76	-	▲	-	✘	-	✘	-	▲	-	▲	-	▲	-
RDMW 1604 MOT	16	4.76	-	▲	-	▲	-	▲	-	▲	-	✘	-	✘	-

SEMI-ROUGHING & FINISHING | RUNDE WENDESCHNEIDPLATTEN > RD20



Code Produktcode	Typology Typologie	€ (P.V.P)	Dimensions (mm) Abmessungen (mm)							Spare Parts Zubehör	
			α	D	D1	L	D2	M	Z		
080C35290-Z5-07	Arbor	-	90°	80	27	50	60	-	5	P60.140.85	CHT25
100C35290-Z6-07	Arbor	-	90°	100	32	52	70	-	6	P60.140.85	CHT25
125C35290-Z7-07	Arbor	-	90°	125	40	52	90	-	7	P60.140.85	CHT25

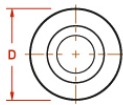

ROUND INSERTS | RUNDE WENDESCHNEIDPLATTEN > RD20

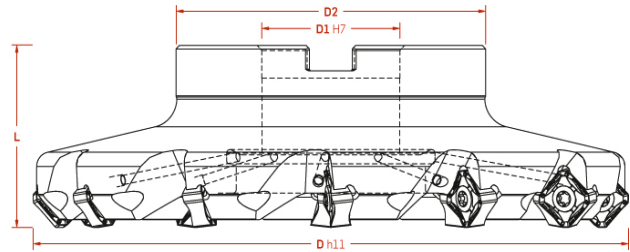

Code Produktcode	Dimensions (mm) Abmessungen (mm)			GRADE											
	D	S	R	P35	€	P30	€	P25	€	P20	€	P10	€	K03	€
RDHT 2006 MOT	20	6.35	-	✘	-	✘	-	✘	-	▲	-	✘	-	✘	-
RDHW 2006 MOT	20	6.35	-	▲	-	✘	-	▲	-	▲	-	✘	-	✘	-
RDMT 2006 MOT	20	6.35	-	▲	-	✘	-	▲	-	✘	-	✘	-	✘	-
RDMW 2006 MOT	20	6.35	-	▲	-	✘	-	▲	-	✘	-	✘	-	✘	-

FACE MILLING | PLANFRÄSEN > SNHX



Code Produktcode	Typology Typologie	€ (P.V.P)	Dimensions (mm) Abmessungen (mm)							Spare Parts Zubehör	
			α	D	D1	L	D2	M	Z		
050A90945-Z4-06	Arbor	-	45°	50	22	40	48	-	4	P40.111.55	CHT15
063A90945-Z6-06	Arbor	-	45°	63	22	40	52	-	6	P40.111.55	CHT15
080A90945-Z7-06	Arbor	-	45°	80	27	50	60	-	7	P40.111.55	CHT15
100A90945-Z8-06	Arbor	-	45°	100	32	50	80	-	8	P40.111.55	CHT15
125A90945-Z9-06	Arbor	-	45°	125	40	50	90	-	9	P40.111.55	CHT15
160A90945-Z12-06	Arbor	-	45°	160	40	55	90	-	12	P40.111.55	CHT15
160A90945-Z16-06	Arbor	-	45°	160	40	50	90	-	16	P40.111.55	CHT15

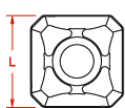

EIGHT EDGES INSERTS | WENDESCHNEIDPLATTEN MIT ACHT SCHNEIDKANTEN > SNHX



Code Produktcode	Dimensions (mm) Abmessungen (mm)			GRADE											
	L	S	R	P35	€	P30	€	P25	€	P20	€	P10	€	K03	€
SNHX 1206 ANEN-LP	12.70	6	-	✘	-	▲	-	✘	-	▲	-	✘	-	✘	-
SNHX 1206 ANSN-MP	12.70	6	-	✘	-	▲	-	✘	-	▲	-	▲	-	✘	-

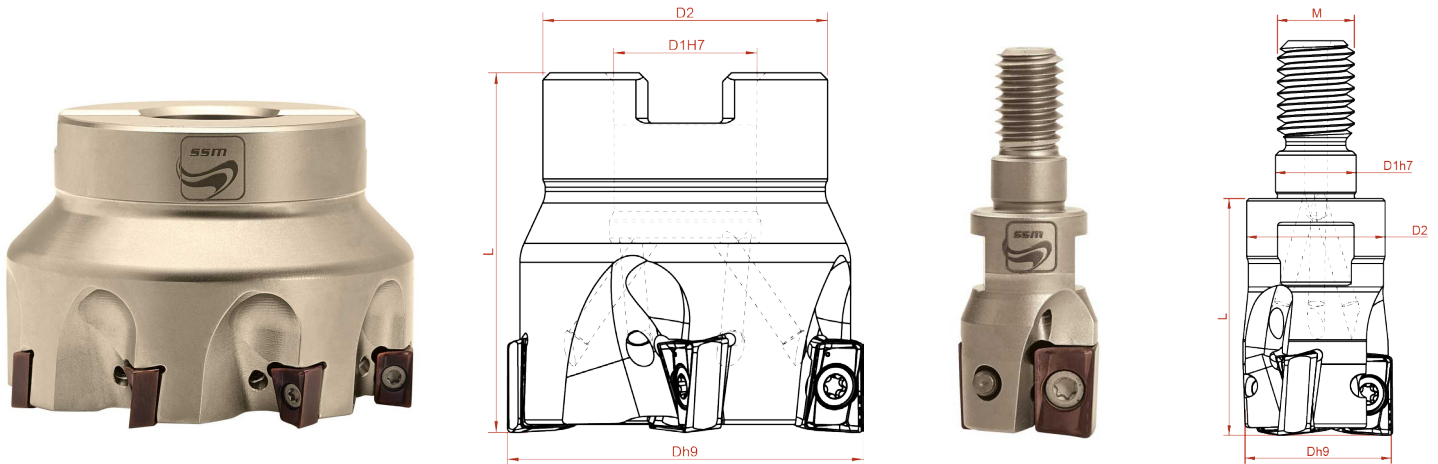





FACE MILLING | PLANFRÄSEN > ANHX10

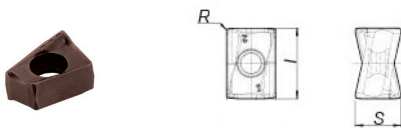

Code Produktcode	Typology Typologie	€ (P.V.P)	Dimensions (mm) Abmessungen (mm)							Spare Parts Zubehör	
			α	D	D1	L	D2	M	Z		
040A17190-Z5-07	Arbor	-	90°	40	16	40	32	-	5	P30.83.43	CHT9
050A17190-Z7-07	Arbor	-	90°	50	22	40	42	-	7	P30.83.43	CHT9
063A17190-Z7-07	Arbor	-	90°	63	22	40	48	-	7	P30.83.43	CHT9
063A17190-Z9-07	Arbor	-	90°	63	22	40	48	-	9	P30.83.43	CHT9
016R17190-Z2-06-M08	Modular	-	90°	16	8,5	25	13	M08	2	P30.83.43	CHT9
020R17190-Z3-06-M10	Modular	-	90°	20	10,5	30	18	M10	3	P30.83.43	CHT9
025R17190-Z3-06-M12	Modular	-	90°	25	12,5	35	21	M12	3	P30.83.43	CHT9
032R17190-Z5-06-M16	Modular	-	90°	32	17	35	29	M16	5	P30.83.43	CHT9



RETANGULAR INSERTS | RECHTECKIGE WENDESCHNEIDPLATTEN > ANHX10



Code Produktcode	Dimensions (mm) Abmessungen (mm)			GRADE											
	L	S	R	P35	€	P30	€	P25	€	P20	€	P10	€	K03	€
ANHX 100405 PNR-LP	10	6.2	0.5		-		-		-		-		-		-

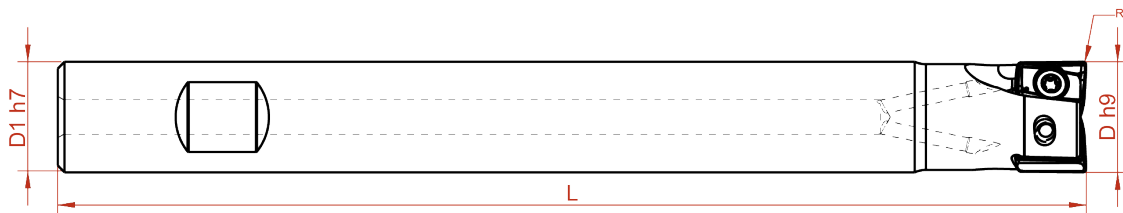





FACE MILLING | PLANFRÄSEN > ANHX10

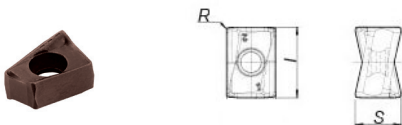

Code Produktcode	Typology Typologie	€ (P.V.P)	Dimensions (mm) Abmessungen (mm)							Spare Parts Zubehör	
			α	D	D1	L	D2	M	Z		
016W17190-Z2-06-90	Haste Shank	-	90°	16	16	90	-	-	2	P30.83.43	CHT9
016W17190-Z2-06-150	Haste Shank	-	90°	16	16	150	-	-	2	P30.83.43	CHT9
018W17190-Z2-06-90	Haste Shank	-	90°	18	16	90	-	-	2	P30.83.43	CHT9
020W17190-Z3-06-150	Haste Shank	-	90°	20	20	150	-	-	3	P30.83.43	CHT9
025W17190-Z3-06-115	Haste Shank	-	90°	25	25	115	-	-	3	P30.83.43	CHT9
025W17190-Z3-06-150	Haste Shank	-	90°	25	25	150	-	-	3	P30.83.43	CHT9
025W17190-Z4-06-150	Haste Shank	-	90°	25	25	150	-	-	4	P30.83.43	CHT9
032W17190-Z3-06-125	Haste Shank	-	90°	32	32	125	-	-	3	P30.83.43	CHT9
032W17190-Z4-06-125	Haste Shank	-	90°	32	32	125	-	-	4	P30.83.43	CHT9



RETANGULAR INSERTS | RECHTECKIGE WENDESCHNEIDPLATTEN > ANHX10



Code Produktcode	Dimensions (mm) Abmessungen (mm)			GRADE											
	L	S	R	P35	€	P30	€	P25	€	P20	€	P10	€	K03	€
ANHX 100405 PNR-LP	10	6.2	0.5		-		-		-		-		-		-

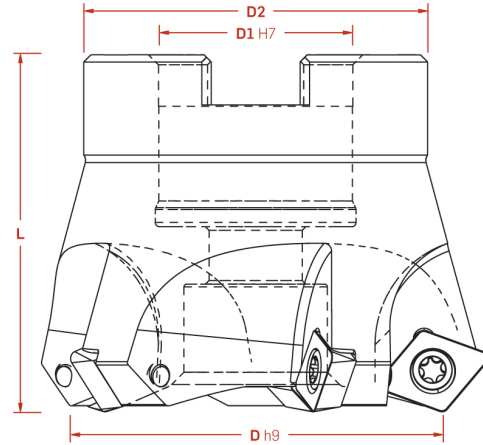





FACE MILLING | PLANFRÄSEN > XD10-R

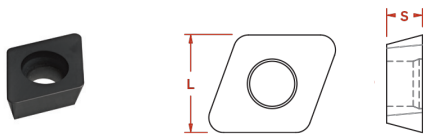

Code Produktcode	Typology Typologie	€ (P.V.P)	Dimensions (mm) Abmessungen (mm)							Spare Parts Zubehör	
			α	D	D1	L	D2	M	Z		
052A50460-Z5-05	Arbor	-	60°	52	27	50	48	-	5	P35.93.53	CHT15
080A50460-Z7-05	Arbor	-	60°	80	27	50	60	-	7	P35.93.53	CHT15



RHOMBIC INSERTS | RHOMBISCHE WENDESCHNEIDPLATTEN > XD10-R

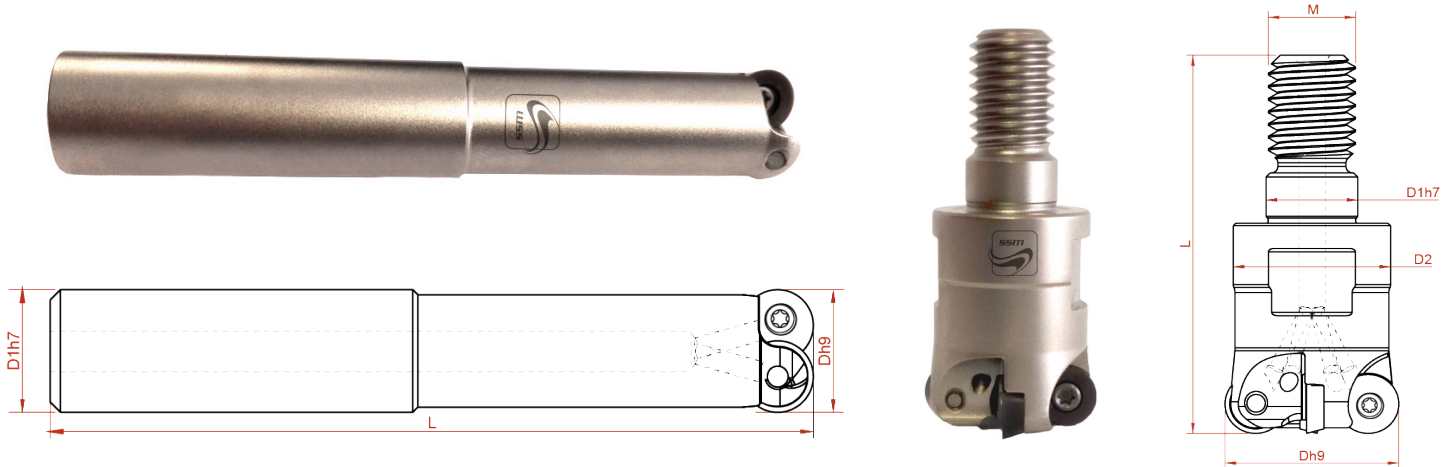

Code Produktcode	Dimensions (mm) Abmessungen (mm)			GRADE											
	L	S	R	P35	€	P30	€	P25	€	P20	€	P10	€	K03	€
XDHW 10T310	10	3.97	-		-		-		-		-		-		-

FINISHING | SCHLICHTEN > RD07



Code Produktcode	Typology Typologie	€ (P.V.P)	Dimensions (mm) Abmessungen (mm)							Spare Parts Zubehör	
			α	D	D1	L	D2	M	Z		
012G54290-Z2-L75	Haste Shank	-	90°	12	12	75	-	-	2	P25.40.30	CHT7
Ø20R54290-Z4-M10	Modular	-	90°	20	10.5	28	18	M10	4	P25.54.33	CHT7

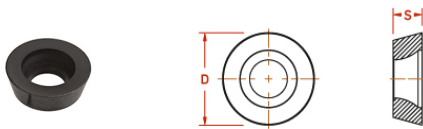

ROUND INSERTS | RUNDE WENDESCHNEIDPLATTEN > RD07



Code Produktcode	Dimensions (mm) Abmessungen (mm)			GRADE											
	D	S	R	P35	€	P30	€	P25	€	P20	€	P10	€	K03	€
RDHW 0702 MOT	7	2.38	-		-		-		-		-		-		-
RDHW 07T1 MOE	7	2.38	-		-		-		-		-		-		-

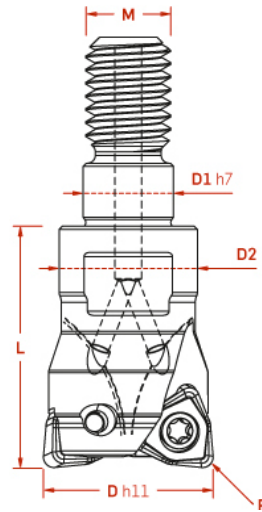





FINISHING | SCHLICHTEN > WNHU

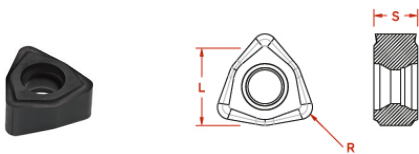

Code Produktcode	Typology Typologie	€ (P.V.P)	Dimensions (mm) Abmessungen (mm)							Spare Parts Zubehör	
			α	D	D1	L	D2	M	Z		
016R09495-Z2-07-M08	Modular	-	95°	16	8,5	28	13	M08	2	P25.70.33	CHT7
020R09495-Z3-07-M10	Modular	-	95°	20	10,5	30	18	M10	3	P25.70.33	CHT7
025R09495-Z4-07-M12	Modular	-	95°	25	12,5	30	21	M12	4	P25.70.33	CHT7
035R09495-Z5-07-M16	Modular	-	95°	35	17	36	29	M16	5	P25.70.33	CHT7
042R09495-Z6-07-M16	Modular	-	95°	42	17	36	29	M16	6	P25.70.33	CHT7



SIX EDGES INSERTS | WENDESCHNEIDPLATTEN MIT SECHS SCHNEIDKANTEN > WNHU

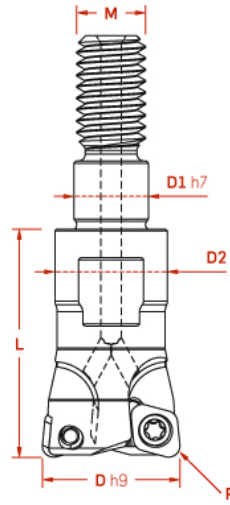

Code Produktcode	Dimensions (mm) Abmessungen (mm)			GRADE											
	L	S	R	P35	€	P30	€	P25	€	P20	€	P10	€	K03	€
WNHU 04T310	6.35	3.97	1		-		-		-		-		-		-

FINISHING | SCHLICHTEN > XD04



Code Produktcode	Typology Typologie	€ (P.V.P)	Dimensions (mm) Abmessungen (mm)							Spare Parts Zubehör	
			α	D	D1	L	D2	M	Z		
010R01495-Z2-09-M06	Modular	-	95°	10	6.50	20	9.80	M06	2	P18.36.27	CHT6
012R01495-Z2-09-M06	Modular	-	95°	12	6.50	20	9.80	M06	2	P18.36.27	CHT6
016R01495-Z3-07-M08	Modular	-	95°	16	8.5	23	13	M08	3	P18.36.27	CHT6

RHOMBIC INSERTS | RHOMBISCHE WENDESCHNEIDPLATTEN > XD04

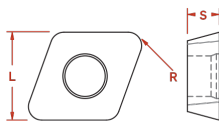

Code Produktcode	Dimensions (mm) Abmessungen (mm)			GRADE											
	L	S	R	P35	€	P30	€	P25	€	P20	€	P10	€	K03	€
XDHW 040105 DLC	4	1.59	0.5	✘	-	✘	-	✘	-	✘	-	✘	-	▲	-
XDHW 040110	4	1.59	1	✘	-	✘	-	▲	-	✘	-	▲	-	▲	-
XDHW 040110 DLC	4	1.59	1	✘	-	✘	-	✘	-	✘	-	✘	-	▲	-

FINISHING | SCHLICHTEN > XD06

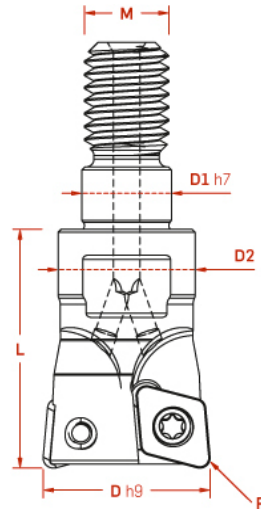

Code Produktcode	Typology Typologie	€ (P.V.P)	Dimensions (mm) Abmessungen (mm)							Spare Parts Zubehör	
			α	D	D1	L	D2	M	Z		
016R00495-Z2-07-M08	Modular	-	95°	16	8,5	23	13	M08	2	P25.54.33	CHT7
020R00495-Z3-07-M10	Modular	-	95°	20	10,5	28	18	M10	3	P25.70.33	CHT7
025R00495-Z3-07-M12	Modular	-	95°	25	12,5	30	21	M12	3	P25.70.33	CHT7
025R00495-Z4-07-M12	Modular	-	95°	25	12,5	30	21	M12	4	P25.70.33	CHT7

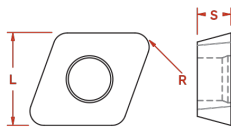

RHOMBIC INSERTS | RHOMBISCHE WENDESCHNEIDPLATTEN > XD06



Code Produktcode	Dimensions (mm) Abmessungen (mm)			GRADE											
	L	S	R	P35	€	P30	€	P25	€	P20	€	P10	€	K03	€
XDHW 060210	6.5	2.38	1	▲	-	✘	-	▲	-	✘	-	▲	-	▲	-
XDHW 060210 DLC	6.5	2.38	1	✘	-	✘	-	✘	-	✘	-	✘	-	▲	-







FINISHING | SCHLICHTEN >XD10

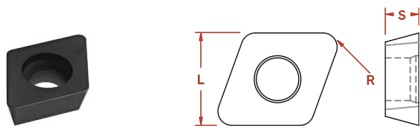

Code Produktcode	Typology Typologie	€ (P.V.P)	Dimensions (mm) Abmessungen (mm)							Spare Parts Zubehör	
			α	D	D1	L	D2	M	Z		
025R50495-Z2-07-M12	Modular	-	95°	25	12,5	35	21	M12	2	P35.67.53	CHT15
035R50495-Z3-07-M16	Modular	-	95°	35	17	43	29	M16	3	P35.93.53	CHT15
042R50495-Z4-07-M16	Modular	-	95°	42	17	43	29	M16	4	P35.93.53	CHT15
052A50495-Z5-07	Arbor	-	95°	52	22	50	40	-	5	P35.93.53	CHT15
066A50495-Z6-07	Arbor	-	95°	66	27	50	48	-	6	P35.93.53	CHT15
080A50495-Z7-07	Arbor	-	95°	80	27	50	60	-	7	P35.93.53	CHT15



RHOMBIC INSERTS | RHOMBISCHE WENDESCHNEIDPLATTEN > XD10

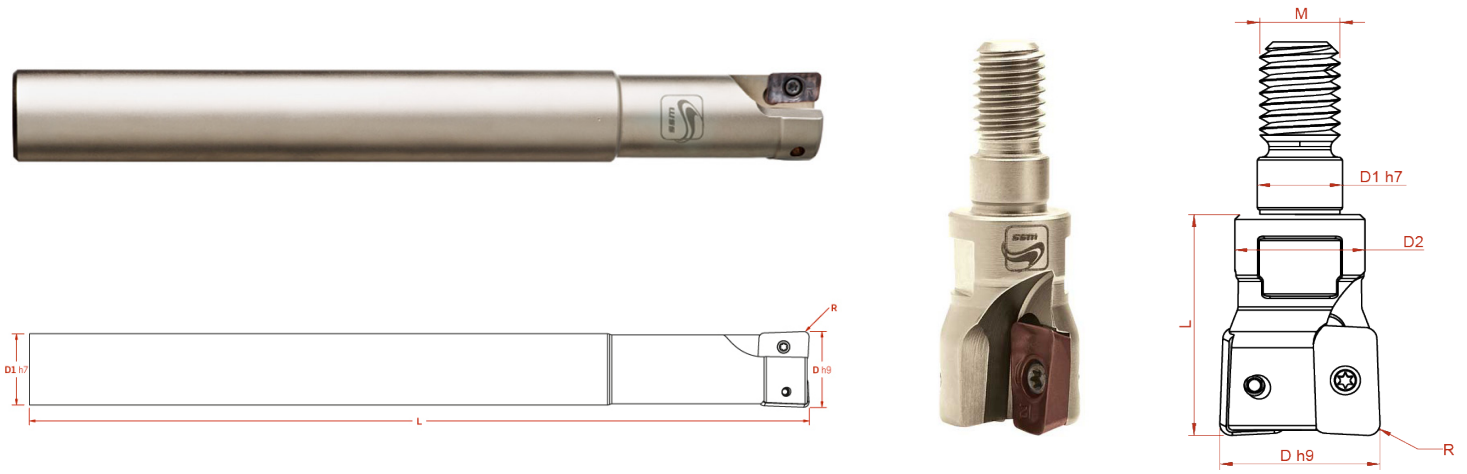

Code Produktcode	Dimensions (mm) Abmessungen (mm)			GRADE											
	L	S	R	P35	€	P30	€	P25	€	P20	€	P10	€	K03	€
XDHW 10T310	10	3.97	1		-		-		-		-		-		-

MULTIPURPOSE | MULTIFUNKTIONSWERKZEUGE > APMT11



Code Produktcode	Typology Typologie	€ (P.V.P)	Dimensions (mm) Abmessungen (mm)							Spare Parts Zubehör	
			α	D	D1	L	D2	M	Z		
017G17892-Z2-175	Haste Shank	-	92°	17	16	175	-	-	2	P25.54.33	CHT7
020G17892-Z2-175	Haste Shank	-	92°	20	20	175	-	-	2	P25.54.33	CHT7
021G17892-Z2-175	Haste Shank	-	92°	21	20	175	-	-	2	P25.54.33	CHT7
025G17892-Z3-175	Haste Shank	-	92°	25	25	175	-	-	3	P25.54.33	CHT7
026G17892-Z3-200	Haste Shank	-	92°	26	25	200	-	-	3	P25.54.33	CHT7
033G17892-Z4-175	Haste Shank	-	92°	33	32	175	-	-	4	P25.54.33	CHT7
016R17892-Z2-M08	Modular	-	92°	16	8.5	23	15	M08	2	P25.54.33	CHT7
020R17892-Z2-M10	Modular	-	92°	20	10.5	28	18	M10	2	P25.54.33	CHT7
021R17892-Z2-M10	Modular	-	92°	21	10.5	28	18	M10	2	P25.54.33	CHT7
025R17892-Z3-M12	Modular	-	92°	25	12.5	30	21	M12	3	P25.54.33	CHT7
026R17892-Z3-M12	Modular	-	92°	26	12.5	30	21	M12	3	P25.54.33	CHT7

RECTANGULAR INSERTS | RECHTECKIGE WENDESCHNEIDPLATTEN > APMT11



Code Produktcode	Dimensions (mm) Abmessungen (mm)			GRADE											
	L	S	R	P35	€	P30	€	P25	€	P20	€	P10	€	K03	€
APMT 11T312 R-MM	11.2	3.6	1.2	✘	-	▲	-	✘	-	✘	-	✘	-	▲	-
APMT11T308R-MM	11.2	3.6	0.8	✘	-	▲	-	✘	-	✘	-	✘	-	▲	-



Stock | aus Lagervorrat lieferbar





Available under request | auf Anfrage erhältlich



Not available | Nicht verfügbar

MULTIPURPOSE | MULTIFUNKTIONSWERKZEUGE > APMT06



Code Produktcode	Typology Typologie	€ (P.V.P)	Dimensions (mm) Abmessungen (mm)							Spare Parts Zubehör	
			α	D	D1	L	D2	M	Z		
010G17692-Z2-05-125	Haste Shank	-	92°	10	10	125	-	-	2	P18.36.27	CHT6
011G17692-Z2-05-125	Haste Shank	-	92°	11	10	125	-	-	2	P18.36.27	CHT6
012G17692-Z2-05-125	Haste Shank	-	92°	12	12	125	-	-	2	P18.36.27	CHT6
013G17692-Z2-05-125	Haste Shank	-	92°	13	12	125	-	-	2	P18.36.27	CHT6

RECTANGULAR INSERTS | RECHTECKIGE WENDESCHNEIDPLATTEN > APMT06



Code Produktcode	Dimensions (mm) Abmessungen (mm)			GRADE											
	L	S	R	P35	€	P30	€	P25	€	P20	€	P10	€	K03	€
APMT 0602 PDSR-MM	6.70	2.60	0.40	<input checked="" type="checkbox"/>	-	<input checked="" type="checkbox"/>	-	<input checked="" type="checkbox"/>	-	<input checked="" type="checkbox"/>	-	<input checked="" type="checkbox"/>	-	<input checked="" type="checkbox"/>	-

MULTIPURPOSE NON FERROUS MATERIALS | MULTIFUNKTIONS-NE-MATERIALIEN > VCGT

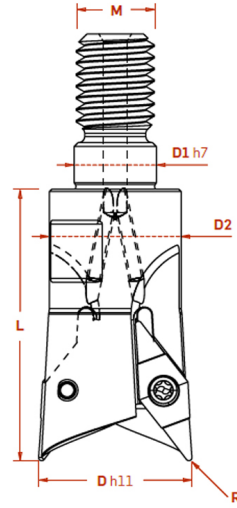

Code Produktcode	Typology Typologie	€ (P.V.P)	Dimensions (mm) Abmessungen (mm)							Spare Parts Zubehör	
			α	D	D1	L	D2	M	Z		
016R18093-Z2-M08	Modular	-	93°	16	8.5	35	13	M08	2	P25.54.33	CHT7
020R18093-Z2-M10	Modular	-	93°	20	10.5	35	17	M10	2	P25.54.33	CHT7

RHOMBIC INSERTS | RAUTENFÖRMIGE EINSÄTZE > VCGT

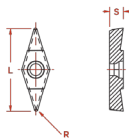

Code Produktcode	Dimensions (mm) Abmessungen (mm)			GRADE											
	L	S	R	P35	€	P30	€	P25	€	P20	€	P10	€	K03	€
VCGT 110301 FS	20.00	3.18	0.10	▲	-	▲	-	✘	-	✘	-	✘	-	✘	-
VCGT 110302 FS	20.00	3.18	0.20	▲	-	▲	-	✘	-	✘	-	✘	-	✘	-
VCGT 110304 FS	20.00	3.18	0.40	▲	-	▲	-	✘	-	✘	-	✘	-	✘	-
VCGT 110308 LN	20.00	3.18	0.80	▲	-	✘	-	✘	-	✘	-	✘	-	✘	-

HOLDERS | SPANNELEMENT > M06 | M08 | M10 | M12 | M16

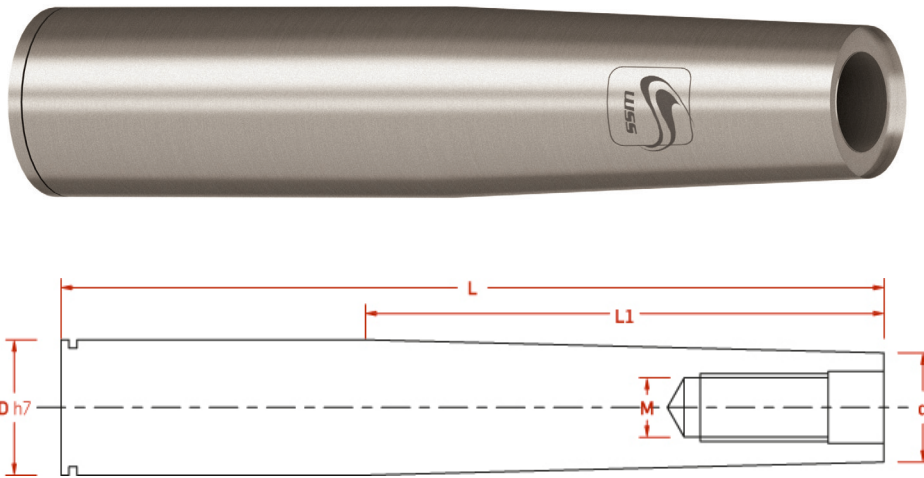

M06		€ (P.V.P)	Dimensions (mm) Abmessungen (mm)			
Code Produktcode	D		L	M	L1	d
50P06-16-9.8	-	16	100	6	50	9.8
75P06-16-9.8	-	16	125	6	75	9.8

M08		€ (P.V.P)	Dimensions (mm) Abmessungen (mm)			
Code Produktcode	D		L	M	L1	d
50P08-16-13	-	16	100	8	50	13
75P08-16-13	-	16	125	8	75	13
100P08-16-13	-	16	150	8	100	13































M10		€ (P.V.P)	Dimensions (mm) Abmessungen (mm)			
Code Produktcode	D		L	M	L1	d
50P10-20-18	-	20	100	10	50	18
75P10-20-18	-	20	125	10	75	18
100P10-20-18	-	20	150	10	100	18

M12		€ (P.V.P)	Dimensions (mm) Abmessungen (mm)			
Code Produktcode	D		L	M	L1	d
50P12-25-21	-	25	100	12	50	21
75P12-25-21	-	25	125	12	75	21
100P12-25-21	-	25	150	12	100	21

M16		€ (P.V.P)	Dimensions (mm) Abmessungen (mm)			
Code Produktcode	D		L	M	L1	d
25P16-32-29	-	32	75	16	25	29
50P16-32-29	-	32	100	16	50	29
100P16-32-29	-	32	150	16	100	29
150P16-32-29	-	32	200	16	150	29

SPARE PARTS | ZUBEHÖR



SCREWDRIVERS SCHRAUBENDREHER	€ (P.V.P)		
Ref. Code			
CHT6-B	-		
CHT6-C	-		
CHT7-B	-		
CHT7-C	-		
CHT8-B	-		
CHT8-C	-		
CHT9-B	-		
CHT9-C	-		
CHT10-B	-		
CHT10-C	-		
CHT15-B	-		
CHT15-C	-		
CHT20-B	-		
CHT20-C	-		
CHT25-B	-		
CHT25-C	-		

SCREW SCHRAUBEN	€ (P.V.P)	Dimensões (mm) Dimensions (mm)	
Ref. Code		L	M
P18.36.27	-	3,6	1,8
P25.54.33	-	5,4	2,5
P25.70.33	-	7	2,5
P30.83.43	-	8,3	3
P35.67.53	-	6,7	3,5
P35.71.80	-	7,1	3,5
P35.93.53	-	9,3	3,5
P40.111.55	-	11,1	4
P45.105.66	-	10,5	4,5
P50.120.55	-	12	5
P60.140.85	-	14	6



smart solutions manufacturer[®]
WE MAKE IT REAL.

Zona Industrial de Santiago de Riba-Ul
Rua da Boavista Nrº 529
3720-502 Oliveira de Azeméis
Portugal

T. +351 256 600 887
F. +351 256 600 889

www.ssm.pt

